

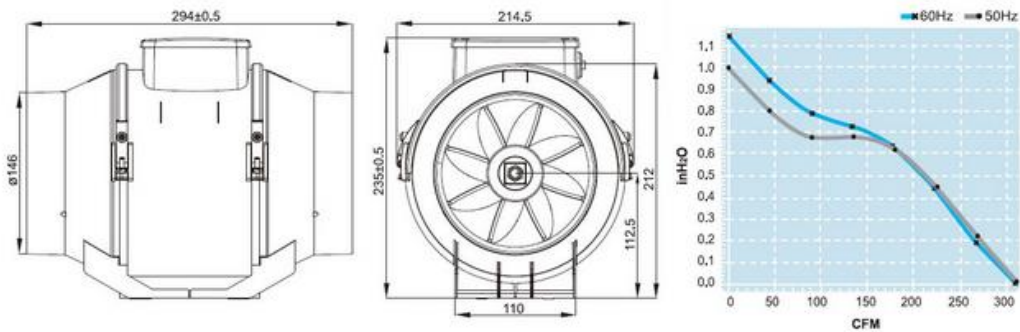

## Duct Fan **DF150P Series**

Frame/Housing:	Plastic
Impeller:	Plastic
Bearing System:	Ball bearing
Motor:	Capacitor run motor
Connection:	Lead wire or terminal type
Protection:	Thermally-Protected
Insulation Resistance:	Above 100MΩ,DC 500V.
Life Expectancy:	Over 40,000 hrs.(at 40°C)
Safety Approval:	CE
Description of Model No.	<b>DF    150    P    23    B    W    H/L</b>
	1       2       3       4       5       6       7

	DF150P11-H	DF150P23-H
Rated Voltage	115 V	230 V
Frequency	50/50 Hz	50/50 Hz
Input Power	65/75 W	65/75 W
Rated Current	0.54/0.65 A	0.27/0.32 A
Locked Current	0.67/0.68 A	0.32/0.33 A
Speed	2000/1900 RPM	2000/1900 RPM
Maximum Air Flow	8.5/8.2 m <sup>3</sup> /min.	8.5/8.2 m <sup>3</sup> /min.
Maximum Air Flow	300/290 CFM	300/290 CFM
Maximum Pressure	26/29 mmH2O	26/29 mmH2O
Maximum Pressure	1.02/1.14 InchH2O	1.02/1.14 InchH2O
Noise	62/61 dB	62/61 dB
Weights	2.6 kg	2.6 kg



SAFETY APPROVAL

